



Operation Instruction



1/3" CCD Standard/High Resolution Digital Color Box Camera EQ200E/300E

Operation Instruction

© 2008 EverFocus Electronics Corp

Please read this manual first for correct installation and operation. This manual should be retained for future reference. The information in this manual was current when published. The manufacturer reserves the right to revise and improve its products. All specifications are therefore subject to change without notice.

All rights reserved. No part of the contents of this manual may be reproduced or transmitted in any form or by any means without written permission of the EverFocus Electronics Corporation.

Precautions

1. Do not place any object on top of the cover.
2. Be careful when handling the camera, do not drop it or subject it to strong shock or vibration to prevent any damages to it. Do not disassemble it or place it on an unstable base.
3. Install the camera away from TV, radio transmitter, magnet, electric motor, transformer, audio speakers because the magnetic fields generate from above devices will distort the video image.
4. Install the camera away from stoves, or other heat generating devices as the high temperature could cause deformation, discoloration or other damages of the camera. Install the camera at where the temperature range will stay between 0°C to 50°C (32°F to 122°F).
5. Never aim the camera at the sun or other extremely bright objects whether it is in use or not.
6. Do not touch the surface of CCD sensor by hand directly. Use a soft cloth to remove the dirt from the camera body. Use lens tissue or a cotton tipped applicator and ethanol to clean the CCD sensor and the camera lens. When the camera is not in use, put the cover cap on the lens mount.
7. All warnings on the products and in the operating instructions should be adhered to.
8. Do not use attachments not recommended by the appliance manufacturer as they may cause hazards.
9. Do not allow anything to rest on the power cord. Do not locate this appliance where the cord will be abused by persons walking on it.
10. Do not overload wall outlets and extension cords as this can result in fire or electric shock.
11. Never push objects of any kind into his appliance through cabinet slots as they may touch dangerous voltage points or short out parts that could result in fire or electric shock.
12. Refer all work related to the installation of this product to qualified service personnel or system installers.

Federal Communication Commission Interference Statement

This equipment has been tested and found to comply with the limits for a Class A digital device, pursuant to Part 15 of the FCC Rules. These limits are designed to provide reasonable protection against harmful interference in a residential installation. This equipment generates, uses and can radiate radio frequency energy and, if not installed and used in accordance with the instructions, may cause harmful interference to radio communications. However, there is no guarantee that interference will not occur in a particular installation. If this equipment does cause harmful interference to radio or television reception, which can be determined by turning the equipment off and on, the user is encouraged to try to correct the interference by one of the following measures:

- Reorient or relocate the receiving antenna.
- Increase the separation between the equipment and receiver.
- Connect the equipment into an outlet on a circuit different from that to which the receiver is connected.
- Consult the dealer or an experienced radio/TV technician for help.

FCC Caution: Any changes or modifications not expressly approved by the party responsible for compliance could void the user's authority to operate this equipment.

This device complies with Part 15 of the FCC Rules. Operation is subject to the following two conditions: (1) This device may not cause harmful interference, and (2) this device must accept any interference received, including interference that may cause undesired operation.

Table of Contents

1. Product Overview.....	5
1.1 Features.....	5
1.2 Accessory Parts List.....	6
1.3 Specifications.....	7
1.4 Dimensions.....	8
1.5 Back Panel Overview.....	8
1.6 Camera Setting DIP Switch.....	9
2. Installation.....	10
2.1 Plug the Power.....	10
2.2 Mount the Lens.....	10
2.3 Connect the Video Output.....	10
2.4 Adjust the Lens.....	10

Chapter 1

Product Overview

The new redesigned EverFocus color box camera produces excellent images with 1/3" SONY Super HAD CCD. The EQ series offers cost-effective solutions suitable for all your surveillance applications. The camera includes an adapter ring and it is compatible with both C-mount and CS-mount lenses. In addition, EQ300E/EQ200E provides 24 hours monitoring Day/Night function. Available in high resolution (520TVL) and standard resolution (380TVL).

1.1 Features

- Low light sensitivity 0.4 Lux/F=1.2(AGC ON) is achieved by using the advanced 1/3" SONY super HAD CCD. (EQ300E)
- Low light sensitivity 0.3 Lux/F=1.2(AGC ON) is achieved by using the advanced 1/3" SONY super HAD CCD. (EQ200E)
- 520 TVL (EQ300E) or 380 TVL (EQ200E) of horizontal resolution
- Support video drive and DC drive auto IRIS lens
- Advanced Digital Signal Processor for excellent image quality
- Day/Night function
- BLC, AGC and FL On/Off switchable
- Compatible with both C-mount and CS-mount lens (adapter ring included)
- System available for NTSC or PAL

1.2 Accessory Parts List



Please be careful when you unpack the box due to the electronics devices inside. Check and make sure that you have all the items listed below inside the original box:

- Camera unit x 1
- Operation instructions (this document) x 1
- Mounting kit includes:
 - C adaptor mount ring x 1



- L wrench x 1



- Iris Lens Connector (top) x 1



- Iris Lens Connector (bottom) x 1



Please Note: If an item appears to have been damaged in shipment, replace it properly in its carton and notify the shipper. If any items are missing, notify your EverFocus Electronics Corp. Sales Representative or Customer Service. The shipping carton is the safest container in which the unit may be transported. Save it for possible future use.

1.3 Specifications

Type	EQ200E	EQ300E
Pickup Device	1/3" SONY Super HAD CCD	
Video Format	NTSC or PAL	
Scanning System	NTSC: 525 TV lines, 60 fields/sec	
	PAL: 625 TV lines, 50 fields/sec.	
Picture Elements	510 x 492 (NTSC) ; 500 x 582 (PAL)	768 x 494 (NTSC) ; 752 x 582 (PAL)
Horizontal Resolution	380 TV Lines	520 TV Lines
Sensitivity	0.3 Lux/F=1.2	0.4 Lux/F=1.2
S/N Ratio	Over 48dB (AGC off)	
Electronic Shutter	1/50(1/60)~1/100,000	
Auto iris	Video/Direct Drive switch	
Back Light Comp.	ON/OFF Switch	
Auto Gain Control	ON/OFF Switch	
Flickerless	ON/OFF Switch	
Simple Day/Night	Auto/OFF Switch	
Auto White Balance	Yes	
Gamma Correction	0.45	
Video Output	BNC 1.0Vp-p, 75ohm	
Sync. Mode	Internal sync	
Lens Mount	C/CS mount	
Audio	Optional	
Power Source	3 types: 12VDC only ; 12VDC/24VAC ; 100VAC~240VAC	
Power Consumption	12VDC: 1.6W max.	
	24VAC: 2.2W max.	
	100VAC~240VAC:1.6W max.	
Dimensions	58mm(W) x 55mm(H) x 125mm(D) ; 2.3"(W) x 2.2"(H) x 4.9"(D)	
Weight	0.25kg ; 0.55lbs	
Operating Temperature	0°C~50°C ; 32°F~122°F (20%~80% Humidity)	
Certifications	FCC/CE	

1.4 Dimensions

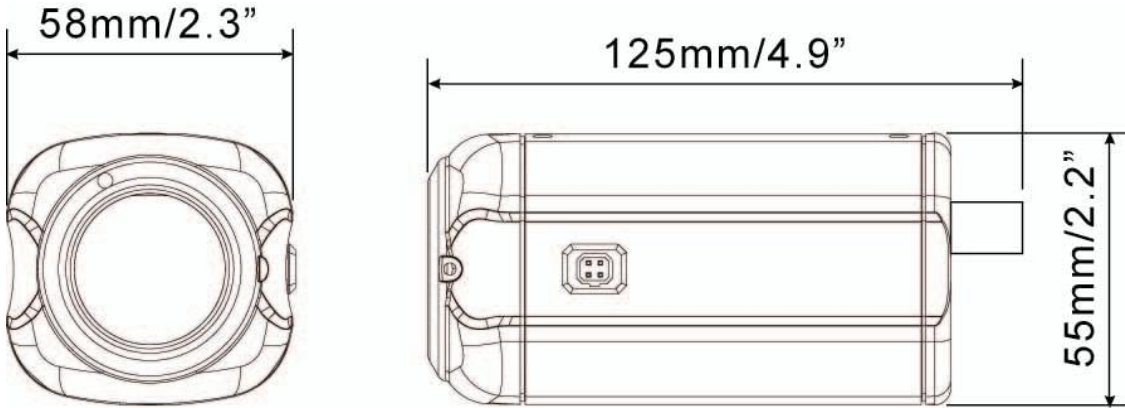

1.5 Back Panel Overview

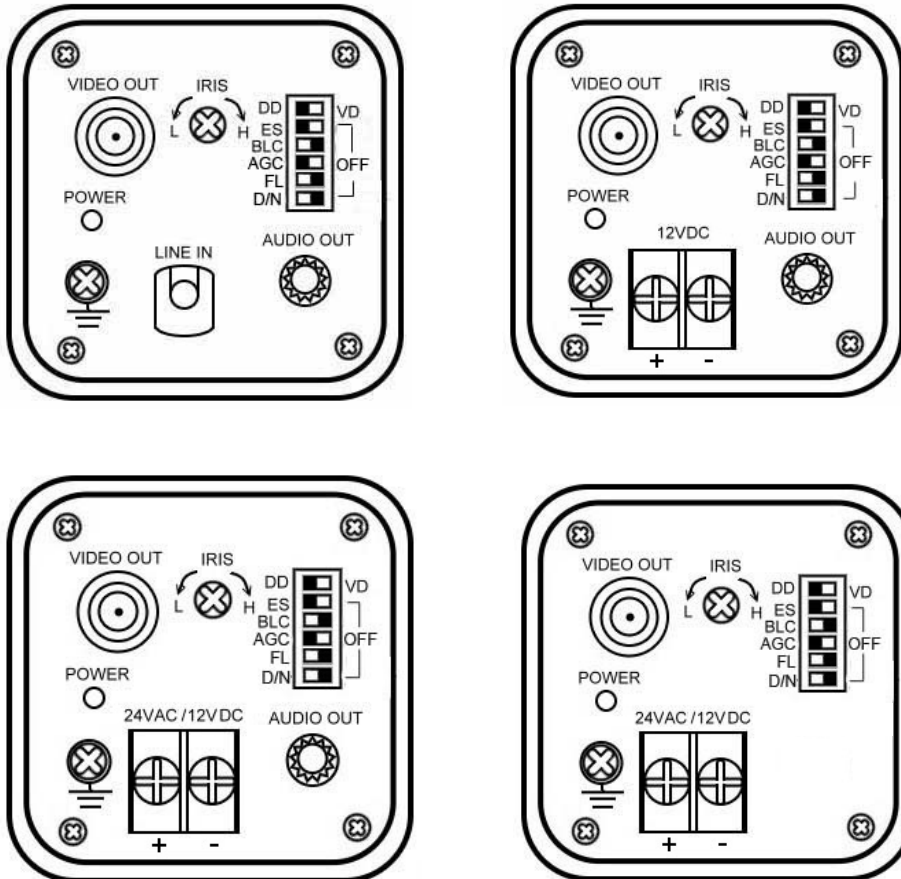

1.6 Camera Setting DIP Switch

① DD/VD

For video drive auto iris lens, please set switch to VD. For Direct Drive iris lens, set switch to DD. Wire the cable of lens to Mini Plug according to the following table:

	<u>Pin1</u>	<u>Pin</u>	<u>Pin 3</u>	<u>Pin 4</u>	
Video Drive	+12V	GND	VD-IRIS	GND	
Direct Drive	Cnt-	Cnt+	Drv+	Drv-	

For Direct Drive iris lens:

Brightness Level can be adjusted from the IRIS level VR on the back panel.

- Turn counterclockwise to L to get darker picture.

- Turn clockwise to H to get brighter picture.

② Electronic Shutter ON/OFF

ES ON: The camera continuously adjusts the shutter speed from 1/60 (NTSC), 1/50 (PAL) second to 1/100,000 second according to the luminance conditions of the scene.

ES OFF: The shutter speed is fixed at 1/60 (NTSC), 1/50 (PAL) second.

Set ES OFF, when auto iris lens is used. Otherwise, turn ES ON for optimum performance.

The default setting is ON.

③ BackLight Compensation ON/OFF

When BLC is turned on, the AGC, ES and IRIS operating point are determined by averaging over the center area instead of entire field-of-view, so that a dimly-lit foreground object at center area can be clearly distinguished from brightly-lit backgrounds.

BLC should not be used unless it is needed to compensate for backlight.

The default setting is OFF.

Note: When ES setting is OFF, then BLC function will be inactive.

④ Automatic Gain Control ON/OFF

AGC ON: The sensitivity increases automatically when light is low.

AGC OFF: A low-noise picture is obtained under a low light condition.

The default setting is ON.

⑤ FL (Flickerless) ON/OFF

When picture flicker fiercely, turn FL on, then the camera will stabilize the speed of electronic shutter at 1/100(NTSC) or 1/120(PAL) automatically, and reduce the flicker immediately.

The default setting is OFF.

⑥ D/N Auto/OFF

Day&Night: When light environment is under 5 Lux, the camera will switch to black and white mode. However, when light environment is over 10 Lux, the camera will switch to color mode.

Please be informed that any D/N switch will result a delay of 4~5 seconds.

The default setting is OFF.

Day&Night OFF: Camera stays in color mode.

Note: when AGC setting is OFF, then D/N function will be inactive.

Chapter 2

Installation

This chapter will describe, in general terms, how to install the EQ300E/EQ200E camera.

STEPS:

1. Plug the power
2. Mount the lens
3. Connect the video output
4. Adjust the lens

2.1 Plug the Power

Plug the power cord to the outlet. Power indicator LED should light if the power source is properly connected.

Warning

- To prevent electrical shock, turn off the electrical power before making electrical connections.
- Do not expose the appliance to water or moisture, nor try to operate it in wet areas.
- Do not connect high voltage power to the camera. It may damage the camera.
- Do not short circuit the power leads and expose the wire when connecting the power supply to the camera

2.2 Mount the Lens

- i. Remove the cover cap from the top of the lens mount.
- ii. If C mount lens is used, please fix the C Mount Ring (the 5 mm thick ring attached in the accessory bag) to the top of the lens mount before mounting the lens.
- iii. Screw the lens firmly onto the lens mount.

2.3 Connect the Video Output

Connect the video output of the camera to a color monitor or other video device through a 75 ohm type coaxial cable with BNC female connector at camera end.

2.4 Adjust the Lens

Once the image appears on the monitor, adjust the focus and diaphragm of the lens to obtain the best picture.

When a lens does not hold focus at both ends of the zoom range, do back focus adjustment as following:

- i. Set the focus ring of the lens to infinity position.
- ii. Take picture of subject at a distance more than 20m away from the camera.
- iii. Loosen the lens mount fixing screw located at right-hand side of the front panel by using the L wrench.

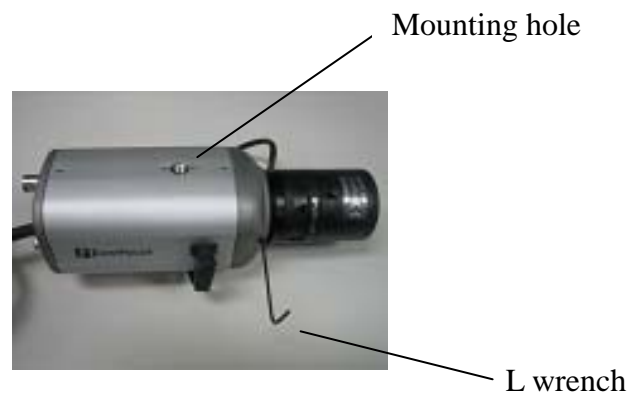

- iv. Turn the lens and the mount together so that the subject is in focus.
- v. Secure the lens mount fixing screw firmly again.

Mount the camera on the mounting bracket by using the mounting hole at bottom or top of the front panel. (Mounting bracket is an optional accessory).

EverFocus Electronics Corp.

Head Office:

12F, No.79 Sec. 1 Shin-Tai Wu Road,
Hsi-Chih, Taipei, Taiwan
TEL: +886-2-26982334
FAX: +886-2-26982380
www.everfocus.com.tw

USA L.A. Office:

1801 Highland Ave. Unit A
Duarte, CA 91010, U.S.A.
TEL: +1-626-844-8888
FAX: +1-626-844-8838
www.everfocus.com

USA N.Y. Office:

415 Oser Avenue Unit S
Hauppauge, NY 11788
TEL: 631-436-5070
FAX: 631-436-5027
www.everfocus.com

Europe Office:

Albert-Einstein-Strasse 1
D-46446 Emmerich, Germany
TEL: 49-2822-9394-0
www.everfocus.de

China Office:

Room 609, Technology Trade Building,
Shangdi Information Industry Base, Haidian
District, Beijing, China 10085
TEL: +86-10-62973336/37/38/39
FAX: +86-10-62971423
www.everfocus.com.cn

Japan Office:

1809 WBG MARIBU East 18F,
2-6 Nakase.Mihama-ku.
Chiba city 261-7118, Japan
TEL: +81-43-212-8188
FAX: +81-43-297-0081
www.everfocus.com



Your EverFocus product is designed and manufactured with high quality materials and components which can be recycled and reused.
This symbol means that electrical and electronic equipment, at their end-of-life, should be disposed of separately from your household waste.
Please, dispose of this equipment at your local community waste collection/recycling centre.
In the European Union there are separate collection systems for used electrical and electronic product.
Please, help us to conserve the environment we live in!

Ihr EverFocus Produkt wurde entwickelt und hergestellt mit qualitativ hochwertigen Materialien und Komponenten, die recycelt und wieder verwendet werden können.
Dieses Symbol bedeutet, dass elektrische und elektronische Geräte am Ende ihrer Nutzungsdauer vom Hausmüll getrennt entsorgt werden sollen.
Bitte entsorgen Sie dieses Gerät bei Ihrer örtlichen kommunalen Sammelstelle oder im Recycling Centre.
Helfen Sie uns bitte, die Umwelt zu erhalten, in der wir leben!



EverFocus®

P/N: MEQ2G01000_Ver.C